

# HX260/HX300

CRAWLER EXCAVATOR



#### Gross Power

HX260 171 kW (229 hp) at 1900 rpm  
HX300 208 kW (279 hp) at 1800 rpm

#### Bucket Capacity

HX260 0.60 - 1.41 m<sup>3</sup>  
HX300 0.45 - 1.63 m<sup>3</sup>

#### Operating Weight

HX260 26170 - 28220 kg  
HX300 31610 - 34620 kg

building a  
comfortable  
tomorrow

**HYUNDAI**

# THE NEXT LEVEL

Hyundai Next Generation crawler excavators are quite simply, Next Level. Equipped with advanced electrohydraulic control systems, the HX260 and HX300 models achieve a minimum of 25% increase in productivity. Next Generation features and smart technologies make these new machines easier to maintain with lower total cost of ownership. Two 12.8-inch full HD touch screens and electric joystick steering make for productive operating, while a 6-camera system and radar offer an unobstructed 360° view for added safety.





# NEXT LEVEL EFFICIENCY

The HX260 and the HX300 are the pinnacle of efficiency in the industry. Their new FEH (Fully Electrohydraulic) system improves fuel consumption by controlling flow rate via an EPOS (Electric Power Optimising System). And because everything from the joysticks to pump are electric, there is no hydraulic loss as in a normal system. So, on top of using less fuel, the machines have faster and more precise control.

## New Hyundai Stage 5 engine



Our new robust engine uses high strength steel with heat and wear resistant material. It consumes up to 7% less fuel vs our A Series machines, and 30% less AdBlue. It also benefits from long maintenance intervals: 1,000-hour filter and oil and DPF ash cleaning over 8,000 hours.

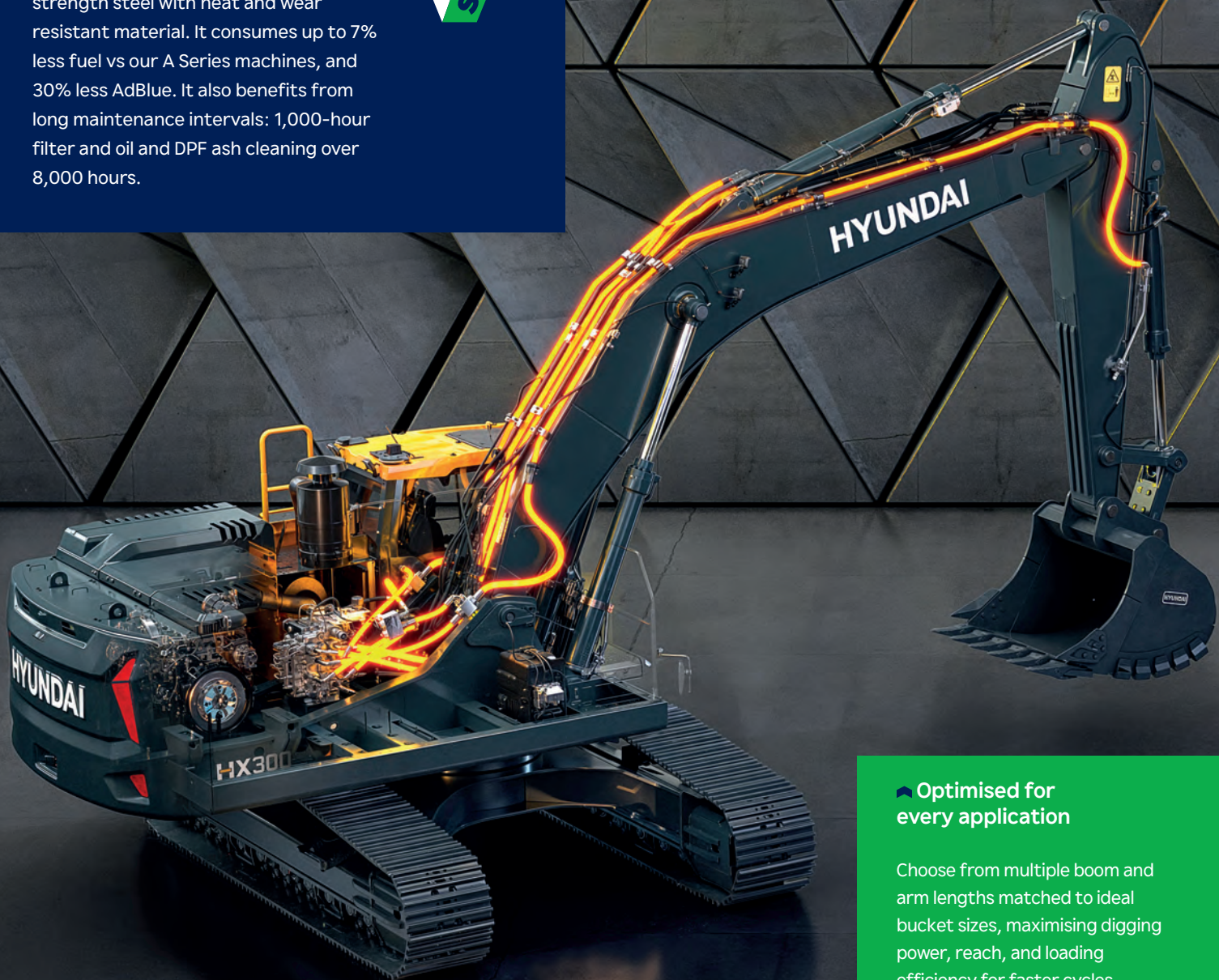

## Optimised for every application

Choose from multiple boom and arm lengths matched to ideal bucket sizes, maximising digging power, reach, and loading efficiency for faster cycles, higher productivity, and optimal performance on every job.

## ► Automatic weighing function

Our next-generation excavators feature an advanced weighing function that automatically measures the material weight inside the bucket. This allows for precise calculation of truck loads and material volumes on-site, enhancing efficiency and accuracy in your operations.

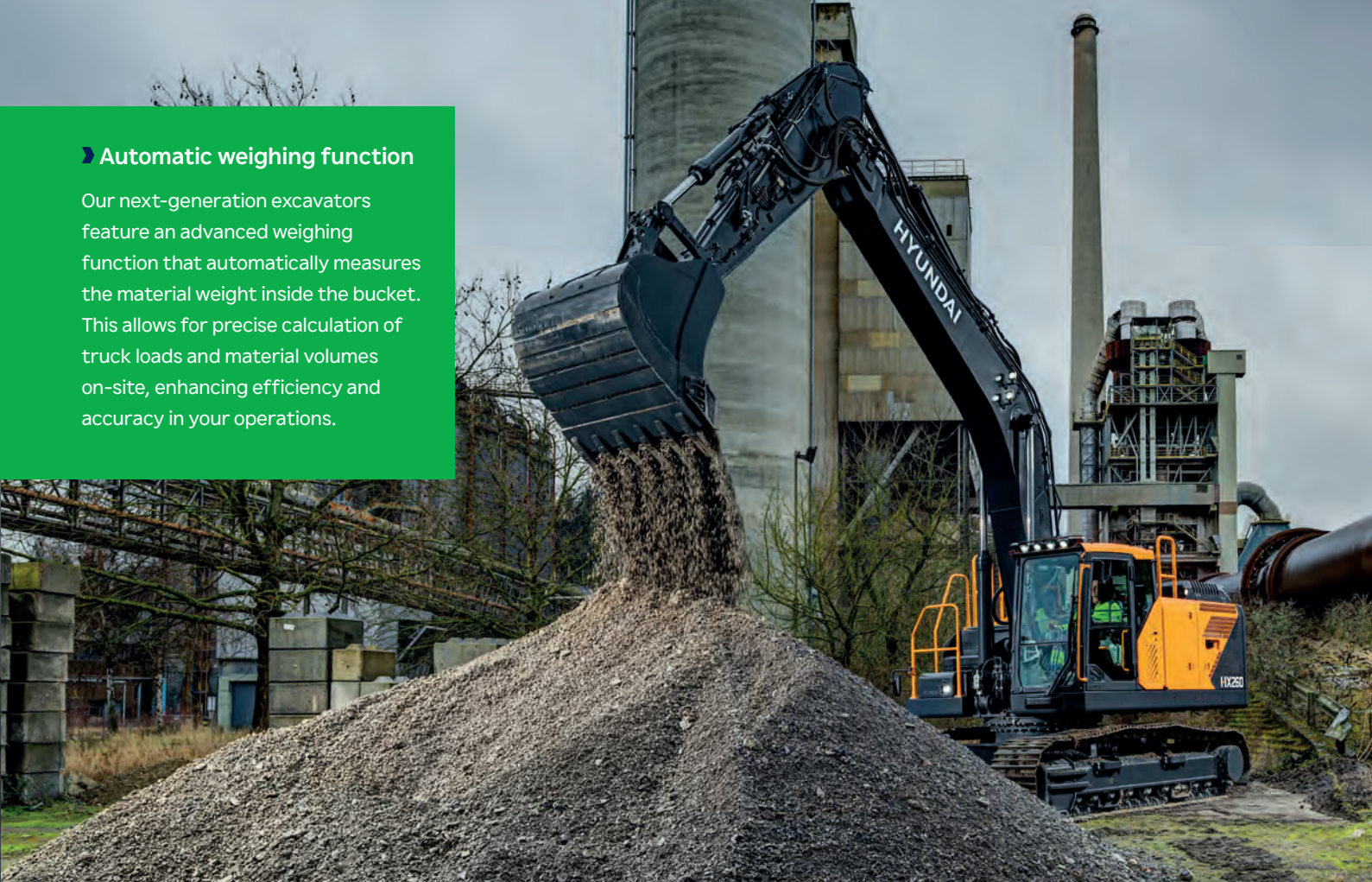

## ► E-boundary

The E-boundary setting can be used to set ceiling, floor and wall limits, which all help to increase productivity and provide greater safety.

## ► Machine guidance

2D MG/MC (Machine Guidance / Control) bucket assist ensures the bucket angle can be automatically stable, preventing soil spillage, while swing assist and grade control allow a swing angle limit to be set, preventing collision with buildings or endangering pedestrians.



## ◀ Lift Assist

Lift Assist provides operators with a visual guide divided into four quadrants, indicating safe zones for moving a load during lifting. This helps prevent overloading and ensures stability. Lift Assist Pro provides additional information with the working zone split into 8 areas.

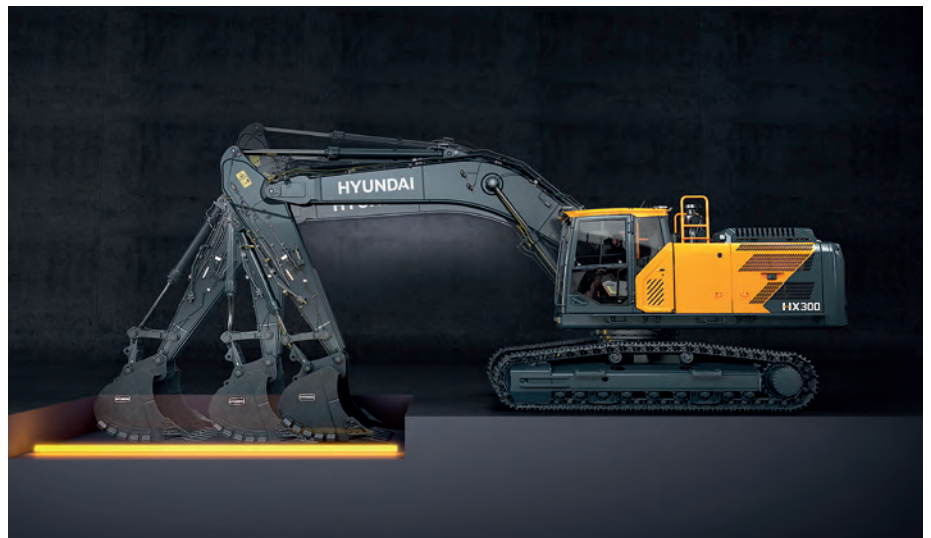

# NEXT LEVEL COMFORT

Our Next Generation excavators set new standards in operator comfort thanks to the new improved controllability and customisability brought about by the FEH (Fully Electrohydraulic) system. On top of the superior control and comfort, the advanced infotainment system with cutting-edge convenience technology completes the efficient working experience and along with many other new features, provides the perfect cab environment.



## ◀ Separate driving pedal

Unlock a new level of convenience with the smart key. Easily locate your machine with the search function and activate the coming/ leaving home light for added safety. Effortlessly control access and start the engine with the touch of a button.

## Digital key **OPTION**

This new option allows the engine to be started and the cabin to be opened and closed from a smart phone, improving user friendliness and comfort even more. The Digital Key can be shared across 6 different users.



## ◀ Attention to detail

New lighting and an easy to clean luxury floor mat add sophistication to the machine interior. A cab welcome light helps operators access and exit the cab safely in poor light conditions.

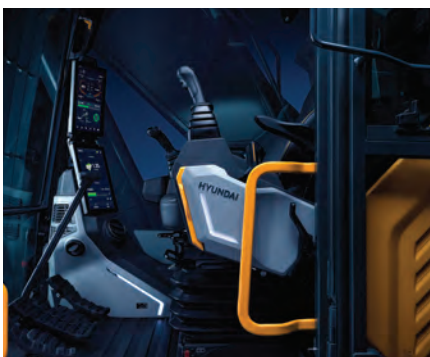

## ▶ High resolution monitors

2 new FHD-grade 12.8" high resolution monitors display different functions and allow the operator to personalise the information shown.





**365  
DAYS**  
COMFORT



#### Comfort pack

With prestige cab branding, the comfort package gives you a premium seat, multi-channel speakers and luxury mat. Convenient left and right stick steering (standard on both machines), allows forward/backward operation and left/right turn driving. Improved lever operability and the electronic hydraulic system help optimise performance and increase safety.

# NEXT LEVEL SAFETY

Hyundai Construction Equipment has set new levels in operator and site safety with an abundance of new technologies. These include: E-boundary, Remote control, SAVM (Smart Around View Monitor), radar object detections and many other important measures. This is all on top of the existing industry leading visibility, visual and auditory support technologies and first-class cluster information.



TECHNOLOGY  
TO KEEP YOU  
**SAFE**



## SAVM (Smart Around View Monitor)

This innovative feature uses 6 cameras located around the machine, including 3 embedded in the counterweight. Using AI, the system automatically detects human presence during machine operation to inform the driver. Images are checked on the 12.8-inch high resolution screen.

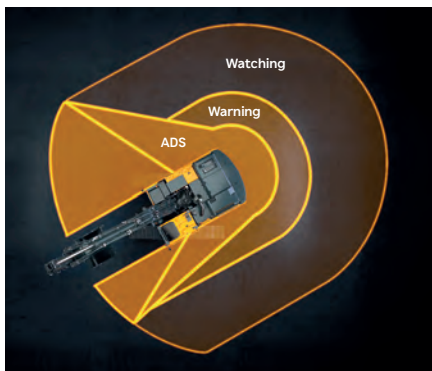

## ADS (Advanced Detection System)

The Advanced Detection System automatically stops the machine when danger arises. If an object enters the warning zone, the system slows or stops the machine, alerting the operator in advance.



## 4-corner beacon system

The 4-corner cab-mounted warning beacons provide 360-degree visibility, enhancing safety around the machine. As an extra warning aid, an external microphone allows the operator to communicate outside of the cab.



## Superior worksite awareness

The wide lower cabin door and full mirror package provide exceptional visibility, enhancing safety and operator confidence.



### Activate Auto Safety Check

The Auto Safety Lock prevents unintended operation due to the excavator not being controlled solely by the RCV lever.

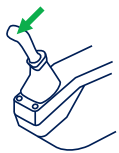

RCV lever is pressed



Unlock safety lever

Turn on indicator lamp



Activate "auto safety lock"

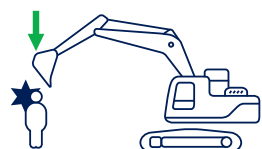

Excavator is not controlled by RCV lever and prevents unintended operation

# NEXT LEVEL SERVICEABILITY

Hyundai construction machines already have some of the highest levels of serviceability in the industry, but the HX260 and HX300 take them a step further. On top of greater machine and component durability with less maintenance needs and greater servicing accessibility, new Hyundai technologies further improve machine monitoring to keep you informed about machine health and improve serviceability.

## ► Robust design

The strong upper and lower structure can withstand external impacts and high-load work. Optional double or full track guards give additional protection when operating in harsh environments.



## ► Increased protection

The new machines have been smartly designed to withstand even higher impacts against the upper structure, boom and dipper. We've also added better protection for the hydraulic lines.



### Reversible fan

The reversing fan keeps the cooling package, clean of debris ensuring optimum cooling performance.

### Improved low temperature start-up

The support system heats the coolant with an electric heating wire inside the engine via an external power source to increase the internal temperature of the engine, thereby assisting start-up in extremely low-temperature environments.



## Hi MATE

Hi MATE's real-time information allows easy and convenient remote machine monitoring via the Hi MATE website or mobile app.

### Increased productivity

By providing information such as usage and maintenance notification reports, Hi MATE saves time and money by enabling you to plan ahead.

### Improved security

To protect your equipment from theft or unauthorised usage, Hi MATE's geofencing alerts notify you automatically when a machine leaves a predetermined zone.

### EHM (Equipment Health Monitoring)

This new technology enables real-time monitoring of equipment conditions and predicts potential failures to optimise maintenance and operational efficiency.



# PROCARE. MORE CARE FOR YOU AND YOUR MACHINE.

ProCare, Hyundai's tailored maintenance packages work proactively via Hi-MATE by automatically delivering service kits directly to dealers before any service is due. This gives you peace of mind knowing that your machine will be serviced on time, with genuine parts and with no extra costs or inflationary increases. Choose the tailored maintenance package best suited for your needs.

## KEY BENEFITS



Automatically delivered  
filter kits



Oil sampling every  
1,000 hours



Fixed prices  
invoiced upfront



Uptime Centre and  
dealer support



## TAILORED MAINTENANCE PACKAGES

### MainCare

#### Stay ahead on service with Hyundai MainCare

MainCare keeps you ahead of maintenance with predictable costs and zero hassle:

- Lock in your filter costs for up to 4 years or 5,000 hours – no surprises, just smooth running.
- Oil sampling at 1,000 hours helps catch issues early and extend component life.
- Your dealer contacts you when service is due – no chasing, no delays.
- Filters always in stock – ready when you are.
- You choose: service it yourself or let your dealer handle it.

### FullCare

#### Complete coverage and confidence with Hyundai FullCare

Everything you get with MainCare, plus up to 4 years extended warranty at discounted price – for complete coverage and confidence:

- Fixed filter costs.
- Proactive service reminders.
- Oil sampling with expert reports.
- Guaranteed parts availability.
- Extended warranty up to 4 years

# HX260 /HX300

## SPECIFICATIONS

	HX260	HX300
<b>ENGINE</b>		
Maker / Model	Hyundai / DX05	Hyundai / DX08
Type	4 cylinder, water cooled, 4-cycle, turbocharged charge air cooled, direct injection, electronic controlled diesel engine.	6 cylinder, water cooled, 4-cycle, turbocharged charge air cooled, direct injection, electronic controlled diesel engine.
Gross Power	171 kW (229 hp) at 1,900 rpm	208 kW (279 hp) at 1,800 rpm
Net Power	169 kW (226 hp) at 1,900 rpm	207 kW (277 hp) at 1,800 rpm
Peak Torque	955 N-m at 1,400 rpm	1230 N-m at 1,300 rpm
Displacement	5.0 l	7.5 l
<b>HYDRAULIC SYSTEM</b>		
Type	Variable displacement tandem axis piston pumps	Variable displacement tandem axis piston pumps
Max. Flow	2 × 238 lpm	2 × 288 lpm
Rated speed	1,900 rpm	1,800 rpm
Cross-sensing and fuel saving pump system		
<b>HYDRAULIC MOTORS</b>		
Travel	Variable displacement axial piston motor	Variable displacement axial piston motor
Swing	Axial piston motor	Axial piston motor
<b>RELIEF VALVE SETTING</b>		
Maximum pressure	350 kgf/cm <sup>2</sup>	350 kgf/cm <sup>2</sup>
Maximum pressure (power boost)	380 kgf/cm <sup>2</sup>	380 kgf/cm <sup>2</sup>
<b>HYDRAULIC CYLINDERS</b>		
No. of Cylinder Bore × Stroke	Boom (2): Ø130 × 1365 mm	Boom (2): Ø140 × 1450 mm
	Arm (1): Ø145 × 1655 mm	Arm (1): Ø150 × 1670 mm
	Bucket (1): Ø130 × 1080 mm	Bucket (1): Ø135 × 1150 mm
<b>DRIVES &amp; BRAKES</b>		
Drive method	Variable displacement axial piston motor	Variable displacement axial piston motor
Braking system	Automatic spring applied hydraulic released	Automatic spring applied hydraulic released
Max. Drawbar pull	28,820 kgf	27,700 kgf
Max. Travel speed (High / Low)	5.8 km/hr / 3.3 km/hr	5.2 km/hr / 3.0 km/hr
Gradeability	35° (70%)	35° (70%)
Parking Brake	Multi wet disc	Multi wet disc

	HX260	HX300
<b>CONTROL</b>		
Full electro-hydraulic control		
Pilot control	Two joysticks with one safety lever	Two joysticks with one safety lever
	(LH) : Swing and arm,	(LH) : Swing and arm,
	(RH) : Boom and bucket (ISO)	(RH) : Boom and bucket (ISO)
Traveling and steering	Two levers with pedals	Two levers with pedals
Engine throttle	Electric, dial type	Electric, dial type
<b>SWING SYSTEM</b>		
Swing Motor	Fixed displacement axial piston motor	Fixed displacement axial piston motor
Swing Reduction	Planetary gear reduction	Planetary gear reduction
Swing Bearing Lubrication	Grease-bathed	Grease-bathed
Swing Brake	Multi wet disc	Multi wet disc
Swing Speed	10.35 rpm	9.3 rpm
<b>SERVICE REFILL CAPACITIES</b>		
Fuel tank	458 l	500 l
Engine coolant	30.6 l	40 l
Engine oil	26 l	35 l
Hydraulic system (including tank)	276 l	393 l
Hydraulic tank	146 l	164 l
DEF/AdBlue®	572 l	72 l
<b>UNDERCARRIAGE</b>		
Center frame	X - leg type	X - leg type
Track frame	Pentagonal box type	Pentagonal box type
No. of shoes on each side	51 EA	48 EA
No. of carrier roller on each side	2 EA	2 EA
No. of track roller on each side	9 EA	9 EA
No. of rail guard on each side	2 EA	2 EA
<b>AIR CONDITIONING</b>		
The air conditioning system contains fluorinated greenhouse gas refrigerant R134a (Global Warming Potential = 1,430). The system contains 0.70 kg of refrigerant representing a CO <sub>2</sub> equivalent of 1.00 metric tonnes.		
<b>NOISE</b>		
LwA (Guaranteed)	103 dB	104 dB
LpA (Guaranteed)	69 dB	68 dB

# HX260 /HX300

## SPECIFICATIONS

### HX260

#### OPERATING WEIGHT

Operating weight including 5.5 ton counterweight, SAE heaped 1.17 m<sup>3</sup> bucket, lubricant, coolant, full fuel tank, full hydraulic tank, and all standard equipments.

Shoes type			600 mm track shoes	700 mm track shoes	800 mm track shoes	900 mm track shoes	
Boom	Boom	Arm	Operating weight / Ground pressure				
HX260L	5.9 m mono	2.5 m	26260 kg / 0.54 kg/cm <sup>2</sup>	26560 kg / 0.46 kg/cm <sup>2</sup>	26880 kg / 0.4 kg/cm <sup>2</sup>	27150 kg / 0.36 kg/cm <sup>2</sup>	
		3.0 m	26370 kg / 0.54 kg/cm <sup>2</sup>	26660 kg / 0.46 kg/cm <sup>2</sup>	26990 kg / 0.41 kg/cm <sup>2</sup>	27260 kg / 0.36 kg/cm <sup>2</sup>	
		3.5 m	26500 kg / 0.54 kg/cm <sup>2</sup>	26790 kg / 0.47 kg/cm <sup>2</sup>	27110 kg / 0.41 kg/cm <sup>2</sup>	27380 kg / 0.36 kg/cm <sup>2</sup>	
	5.9 m HD mono	3.0 m HD	26530 kg / 0.54 kg/cm <sup>2</sup>	26830 kg / 0.47 kg/cm <sup>2</sup>	27150 kg / 0.41 kg/cm <sup>2</sup>	27420 kg / 0.36 kg/cm <sup>2</sup>	
	2-piece	2.5 m	27100 kg / 0.56 kg/cm <sup>2</sup>	27400 kg / 0.48 kg/cm <sup>2</sup>	27720 kg / 0.42 kg/cm <sup>2</sup>	27990 kg / 0.37 kg/cm <sup>2</sup>	
		3.0 m	27210 kg / 0.56 kg/cm <sup>2</sup>	27500 kg / 0.48 kg/cm <sup>2</sup>	27830 kg / 0.42 kg/cm <sup>2</sup>	28100 kg / 0.37 kg/cm <sup>2</sup>	
		3.5 m	27340 kg / 0.56 kg/cm <sup>2</sup>	27630 kg / 0.48 kg/cm <sup>2</sup>	27950 kg / 0.42 kg/cm <sup>2</sup>	28220 kg / 0.37 kg/cm <sup>2</sup>	
	HX260NL	5.9 m mono	2.5 m	26170 kg / 0.54 kg/cm <sup>2</sup>	26470 kg / 0.46 kg/cm <sup>2</sup>	26790 kg / 0.40 kg/cm <sup>2</sup>	27060 kg / 0.36 kg/cm <sup>2</sup>
			3.0 m	26280 kg / 0.54 kg/cm <sup>2</sup>	26580 kg / 0.46 kg/cm <sup>2</sup>	26900 kg / 0.40 kg/cm <sup>2</sup>	27170 kg / 0.36 kg/cm <sup>2</sup>
3.5 m			26410 kg / 0.54 kg/cm <sup>2</sup>	26700 kg / 0.46 kg/cm <sup>2</sup>	27030 kg / 0.41 kg/cm <sup>2</sup>	27290 kg / 0.36 kg/cm <sup>2</sup>	
5.9 m HD mono		3.0 m HD	26440 kg / 0.54 kg/cm <sup>2</sup>	26740 kg / 0.46 kg/cm <sup>2</sup>	27060 kg / 0.41 kg/cm <sup>2</sup>	27330 kg / 0.36 kg/cm <sup>2</sup>	
2-piece		2.5 m	27010 kg / 0.55 kg/cm <sup>2</sup>	27310 kg / 0.47 kg/cm <sup>2</sup>	27630 kg / 0.41 kg/cm <sup>2</sup>	27900 kg / 0.37 kg/cm <sup>2</sup>	
		3.0 m	27120 kg / 0.56 kg/cm <sup>2</sup>	27420 kg / 0.48 kg/cm <sup>2</sup>	27740 kg / 0.42 kg/cm <sup>2</sup>	28010 kg / 0.37 kg/cm <sup>2</sup>	
		3.5 m	27250 kg / 0.56 kg/cm <sup>2</sup>	27540 kg / 0.48 kg/cm <sup>2</sup>	27870 kg / 0.42 kg/cm <sup>2</sup>	28130 kg / 0.37 kg/cm <sup>2</sup>	

### HX300

#### OPERATING WEIGHT

Operating weight, including 5.4 ton counterweight (6.3 ton for long reach), SAE heaped 1.47 m<sup>3</sup> bucket (0.59 m<sup>3</sup> for long reach), lubricant, coolant, full fuel tank, full hydraulic tank, and all standard equipments.

Shoes type			600 mm track shoes	700 mm track shoes	800 mm track shoes	900 mm track shoes	
Boom	Boom	Arm	Operating weight / Ground pressure				
HX300L	6.245 m mono	2.5 m	31690 kg / 0.63 kg/cm <sup>2</sup>	32320 kg / 0.55 kg/cm <sup>2</sup>	32710 kg / 0.49 kg/cm <sup>2</sup>	33100 kg / 0.44 kg/cm <sup>2</sup>	
		3.1 m	31820 kg / 0.63 kg/cm <sup>2</sup>	32450 kg / 0.55 kg/cm <sup>2</sup>	32840 kg / 0.49 kg/cm <sup>2</sup>	33230 kg / 0.44 kg/cm <sup>2</sup>	
		3.75 m	31990 kg / 0.64 kg/cm <sup>2</sup>	32620 kg / 0.56 kg/cm <sup>2</sup>	33010 kg / 0.49 kg/cm <sup>2</sup>	33400 kg / 0.44 kg/cm <sup>2</sup>	
	6.245 m HD mono	2.85 m HD	32070 kg / 0.64 kg/cm <sup>2</sup>	32700 kg / 0.56 kg/cm <sup>2</sup>	33090 kg / 0.49 kg/cm <sup>2</sup>	33470 kg / 0.44 kg/cm <sup>2</sup>	
		3.1 m HD	32120 kg / 0.64 kg/cm <sup>2</sup>	32750 kg / 0.56 kg/cm <sup>2</sup>	33140 kg / 0.49 kg/cm <sup>2</sup>	33530 kg / 0.44 kg/cm <sup>2</sup>	
	2-piece	2.5 m	32450 kg / 0.64 kg/cm <sup>2</sup>	33080 kg / 0.56 kg/cm <sup>2</sup>	33470 kg / 0.50 kg/cm <sup>2</sup>	33860 kg / 0.45 kg/cm <sup>2</sup>	
		3.1 m	32580 kg / 0.65 kg/cm <sup>2</sup>	33210 kg / 0.57 kg/cm <sup>2</sup>	33600 kg / 0.50 kg/cm <sup>2</sup>	33990 kg / 0.45 kg/cm <sup>2</sup>	
	HX300NL	6.245 m mono	2.5 m	31610 kg / 0.63 kg/cm <sup>2</sup>	32240 kg / 0.55 kg/cm <sup>2</sup>	32630 kg / 0.49 kg/cm <sup>2</sup>	-
			3.1 m	31740 kg / 0.63 kg/cm <sup>2</sup>	32370 kg / 0.55 kg/cm <sup>2</sup>	32760 kg / 0.49 kg/cm <sup>2</sup>	-
3.75 m			31910 kg / 0.63 kg/cm <sup>2</sup>	32540 kg / 0.55 kg/cm <sup>2</sup>	32930 kg / 0.49 kg/cm <sup>2</sup>	-	
6.245 m HD mono		2.85 m HD	31980 kg / 0.64 kg/cm <sup>2</sup>	32620 kg / 0.56 kg/cm <sup>2</sup>	33010 kg / 0.49 kg/cm <sup>2</sup>	-	
		3.1 m HD	32040 kg / 0.64 kg/cm <sup>2</sup>	32670 kg / 0.56 kg/cm <sup>2</sup>	33060 kg / 0.49 kg/cm <sup>2</sup>	-	
2-piece		2.5 m	32370 kg / 0.64 kg/cm <sup>2</sup>	33000 kg / 0.56 kg/cm <sup>2</sup>	33390 kg / 0.50 kg/cm <sup>2</sup>	-	
		3.1 m	32500 kg / 0.65 kg/cm <sup>2</sup>	33130 kg / 0.56 kg/cm <sup>2</sup>	33520 kg / 0.50 kg/cm <sup>2</sup>	-	
HX300LR		10.2 m long reach	7.85 m long reach	33220 kg / 0.66 kg/cm <sup>2</sup>	33850 kg / 0.58 kg/cm <sup>2</sup>	34240 kg / 0.51 kg/cm <sup>2</sup>	34620 kg / 0.46 kg/cm <sup>2</sup>

# HX260 /HX300

## DIMENSIONS

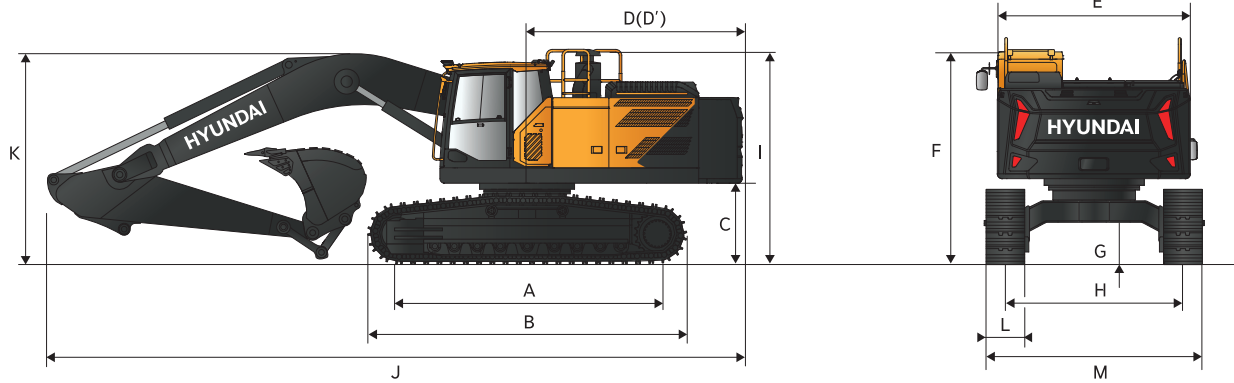

	HX260	HX300
--	-------	-------

Unit : mm

A	<b>Tumbler distance</b>	3835				4040								
B	<b>Overall length of crawler</b>	4628				4946								
*C	<b>Ground clearance of counter weight</b>	1085.5				1132.0								
D	<b>Tail swing radius</b>	3040				3207								
D'	<b>Rear-end length</b>	3040				3207								
E	<b>Overall width of upper structure</b>	2710				2990								
*F	<b>Overall height of cab</b>	3185				3235								
G	<b>Min. Ground clearance</b>	424				473								
H	<b>Track gauge</b>	2600 (HX260L)				2600 (HX300L)								
		2400 (HX260NL)				2400 (HX300NL)								
*I	<b>Overall height guardrail</b>	3304				3347								
	<b>Boom length</b>	5.9 m			2-piece boom			6.245 m			2-piece boom	10.2 m		
		2.5 m	3.0 m	3.5 m	2.5 m	3.0 m	3.5 m	2.5 m	2.85 m	3.1 m	3.75 m	3.1 m	7.85 m	
J	<b>Overall length</b>	10145	10085	10110	10290	10265	10195	10684	10688	10585	10642	10640	14533	
*K	<b>Overall height of boom</b>	<b>Without hose</b>	3080	3015	3380	3094	3115	3459	3448	3570	3316	3519	3470	3430
		<b>With hose</b>	3344	3235	3597	3094	3115	3507	3538	3686	3383	3642	3470	3479
L	<b>Track shoe width</b>			<b>600</b>	<b>700</b>	<b>800</b>	<b>900</b>			<b>600</b>	<b>700</b>	<b>800</b>	<b>900</b>	
M	<b>Undercarriage width</b>	<b>HX260L</b>		3200	3300	3400	3500	<b>HX300L</b>		3200	3300	3400	3500	
		<b>HX260NL</b>		3000	3100	3200	3300	<b>HX300NL</b>		3000	3100	3200	-	

# HX260/HX300 WORKING RANGE

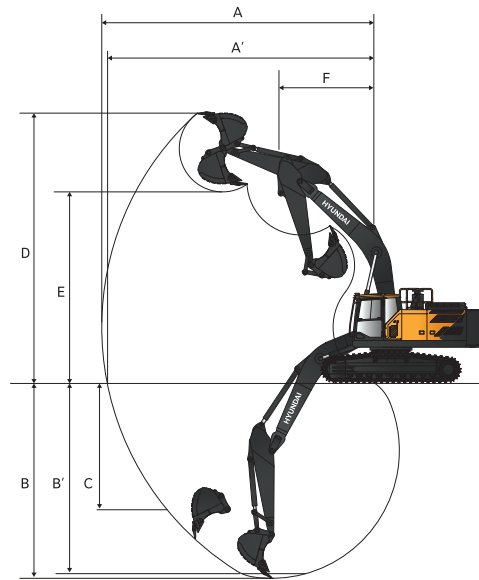

## HX260

Unit : mm

Boom Length	5.9 m			2-piece boom		
Arm Length	2.5 m	3.0 m	3.5 m	2.5 m	3.0 m	3.5 m
A Max. digging reach	9645	10170	10600	9950	10480	10930
A' Max. digging reach on ground	9450	9990	10430	9760	10305	10760
B Max. digging depth	6305	6810	7310	6205	6730	7205
B' Max. digging depth (8' level)	6040	6615	7135	6090	6625	7105
C Max. vertical wall digging depth	6460	6375	6640	6090	6625	7105
D Max. digging height	9355	9770	9890	11060	11580	11875
E Max. dumping height	6650	7025	7170	6205	6730	7205
F Min. swing radius	3730	3715	3755	3080	2940	3280

## HX300

Unit : mm

Boom Length	6.245 m				2-piece boom			10.2 m
Arm Length	2.5 m	2.85 m	3.1 m	3.75 m	2.5 m	3.1 m	3.75 m	7.85 m
A Max. digging reach	10110	10370	10670	11200	10230	10810	11360	18480
A' Max. digging reach on ground	9910	10180	10480	11020	10030	10620	11180	18370
B Max. digging depth	6680	7030	7280	7930	6380	6980	7590	14610
B' Max. digging depth (8' level)	6450	6800	7090	7750	6280	6880	7500	14520
C Max. vertical wall digging depth	5510	5610	6180	6610	5270	5900	6460	13090
D Max. digging height	9910	9900	10210	10290	11520	12010	12360	15060
E Max. dumping height	7010	7040	7300	7420	8440	8920	9280	12820
F Min. swing radius	4200	4050	4020	4070	2950	2900	3110	5890















# HX260L

## LIFTING CAPACITY















 Rating over-front  Rating over-side or 360 degrees

### HX260L















5.9 m boom, 3.0 m arm equipped with 600 mm triple grouser shoe, 5,500 kg counterweight

Lift-point height m		Lift-point radius												A max. Reach		
		1.5 m		3.0 m		4.5 m		6.0 m		7.5 m		9.0 m		Capacity		Reach
																m
7.5 m	kg							6600*	6600*					5260*	5260*	6.66
6.0 m	kg							6750*	6750*	5910*	5310			4990*	4990*	7.68
4.5 m	kg					8870*	8870*	7530*	7380	6870*	5230			4950*	4430	8.32
3.0 m	kg					11270*	10770*	8650*	7050	7390*	5080			5110*	4100	8.64
1.5 m	kg					13310*	10140*	9720*	6740	7310	4930			5460*	3990	8.69
0.0 m	kg			7560*	7560*	14230*	9820*	9990	6530	7180	4810			6030	4070	8.48
-1.5 m	kg	8670*	8670*	13130*	13130*	14090*	9740*	9890	6440	7140	4770			6550	4410	7.98
-3.0 m	kg	14380*	14380*	18000*	18000*	12970*	9820*	9730*	6490					7690*	5170	7.14
-4.5 m	kg			14120*	14120*	10410*	10080*							7610*	7040	5.80

5.9 m boom, 3.0 m arm equipped with 600 mm triple grouser shoe, 5,500 kg counterweight

Lift-point height m		Lift-point radius												A max. Reach		
		1.5 m		3.0 m		4.5 m		6.0 m		7.5 m		9.0 m		Capacity		Reach
																m
7.5 m	kg													4710*	4710*	7.21
6.0 m	kg									6090*	5390			4520*	4520*	8.17
4.5 m	kg							6980*	6980*	6440*	5290			4520*	4100	8.76
3.0 m	kg					10410*	10410*	8160*	7160	7030*	5130	5100*	3860	4680*	3810	9.07
1.5 m	kg					12680*	1030*	9340*	6810	7340	4950	5580	3790	5000*	3710	9.12
0.0 m	kg			8750*	8750*	13970*	9870*	10030	6560	7190	4810			5550*	3780	8.92
-1.5 m	kg	8330*	8330*	12860*	12860*	14200*	9710*	9890	6430	7110	4740			6010	4050	8.45
-3.0 m	kg	13020*	13020*	18760*	18760*	13460*	9740*	9890	6430	7140	4770			6940	4650	7.66
-4.5 m	kg	19070*	19070*	15950*	15950*	11490*	9950*	8400*	6580					7510*	6020	6.43

5.9 m boom, 3.0 m arm equipped with 600 mm triple grouser shoe, 5500 kg counterweight

Lift-point height m		Lift-point radius												A max. Reach		
		1.5 m		3.0 m		4.5 m		6.0 m		7.5 m		9.0 m		Capacity		Reach
																m
9.0 m	kg					7670*	7670*							5660*	5660*	5.53
7.5 m	kg							7270*	7270*					4890*	4890*	7.06
6.0 m	kg					7500*	7500*	7890*	7550*	6740*	5230*			4580*	4580*	8.03
4.5 m	kg					11310*	11310*	8990*	7250*	7030*	5120*			4490*	4040*	8.64
3.0 m	kg					13040*	10490*	9750*	6870*	7390*	4940*			4560*	3750*	8.95
1.5 m	kg					13980*	9800*	10080*	6530*	7190*	4760*	4840*	3660*	4790*	3660*	9.00
0.0 m	kg					13610*	9490*	9830*	6310*	7060*	4640*			5220*	3740*	8.80
-1.5 m	kg			10120*	10120*	12170*	9450*	9390*	6230*	7020*	4610*			5790*	4040*	8.32
-3.0 m	kg					9720*	9580*	7610*	6300*	5050*	4720*			4990*	4700*	7.52

- Lifting capacity is based on ISO 10567.
- Lifting capacity does not exceed 75% of tipping load with the machine on firm, level ground or 87% of full hydraulic capacity.
- The lift-point is where the bucket pivot mounting pin intersects with the arm (without bucket mass).
- (\*) indicates load limited by hydraulic capacity.















# HX260NL

## LIFTING CAPACITY















 Rating over-front  Rating over-side or 360 degrees

### HX260NL















5.9 m boom, 3.0 m arm equipped with 600 mm triple grouser shoe, 5500 kg counterweight

Lift-point height m		Lift-point radius												A max. Reach		
		1.5 m		3.0 m		4.5 m		6.0 m		7.5 m		9.0 m		Capacity		Reach
																m
7.5 m	kg							6600*	6600*					5260*	5260*	6.66
6.0 m	kg							6750*	6750*	5910*	4900			4990*	4700	7.68
4.5 m	kg					8870*	8870*	7530*	6790	6870*	4830			4950*	4080	8.32
3.0 m	kg					11270*	9810	8650*	6470	7390*	4680			5110*	3770	8.64
1.5 m	kg					13310*	9200	9720*	6170	7280	4530			5460*	3660	8.69
0.0 m	kg			7560*	7560*	14230*	8890	9960	5970	7160	4410			6010	3740	8.48
-1.5 m	kg	8670*	8670*	13130*	13130*	14090*	8810	9860	5880	7120	4370			6530	4040	7.98
-3.0 m	kg	14380*	14380*	18000*	17280*	12970*	8890	9730*	5920					7690*	4740	7.14
-4.5 m	kg			14120*	14120*	10410*	9140							7610*	6440	5.80

5.9 m boom, 3.0 m arm equipped with 600 mm triple grouser shoe, 5,500 kg counterweight

Lift-point height m		Lift-point radius												A max. Reach		
		1.5 m		3.0 m		4.5 m		6.0 m		7.5 m		9.0 m		Capacity		Reach
																m
7.5 m	kg													4710*	4710*	7.21
6.0 m	kg									6090*	4980			4520*	4290	8.17
4.5 m	kg							6980*	6910	6440*	4880			4520*	3770	8.76
3.0 m	kg					10410*	10060	8160*	6580	7030*	4720	5100*	3550	4680*	3500	9.07
1.5 m	kg					12680*	9360	9340*	6240	7320	4550	5570	3480	5000*	3410	9.12
0.0 m	kg			8750*	8750*	13970*	8940	10000	5990	7170	4410			5550*	3460	8.92
-1.5 m	kg	8330*	8330*	12860*	12860*	14200*	8780	9860	5870	7090	4340			5990	3710	8.45
-3.0 m	kg	13020*	13020*	18760*	17080*	13460*	8810	9860	5860	7120	4370			6920	4260	7.66
-4.5 m	kg	19070*	19070*	15950*	15950*	11490*	9010	8400*	6020					7510*	5510	6.43

2-piece boom, 3.0 m arm equipped with 600 mm triple grouser shoe, 5500 kg counterweight

Lift-point height m		Lift-point radius												A max. Reach		
		1.5 m		3.0 m		4.5 m		6.0 m		7.5 m		9.0 m		Capacity		Reach
																m
9.0 m	kg					7670*	7670*							5660*	5660*	5.53
7.5 m	kg							7270*	7060*					4890*	4890*	7.06
6.0 m	kg					7500*	7500*	7890*	6950*	6740*	4810*			4580*	4240*	8.03
4.5 m	kg					11310*	10370*	8990*	6660*	7030*	4700*			4490*	3700*	8.64
3.0 m	kg					13040*	9520*	9750*	6280*	7360*	4530*			4560*	3430*	8.95
1.5 m	kg					13980*	8850*	10050*	5950*	7170*	4350*	4840*	3340*	4790*	3340*	9.00
0.0 m	kg					13610*	8550*	9800*	5730*	7040*	4230*			5220*	3410*	8.80
-1.5 m	kg			10120*	10120*	12170*	8510*	9390*	5660*	7000*	4200*			5790*	3690*	8.32
-3.0 m	kg					9720*	8630*	7610*	5720*	5050*	4310*			4990*	4300*	7.52

- Lifting capacity is based on ISO 10567.
- Lifting capacity does not exceed 75% of tipping load with the machine on firm, level ground or 87% of full hydraulic capacity.
- The lift-point is where the bucket pivot mounting pin intersects with the arm (without bucket mass).
- (\*) indicates load limited by hydraulic capacity.











# HX300L

## LIFTING CAPACITY















 Rating over-front  Rating over-side or 360 degrees

### HX300L















6.245 m boom, 2.5 m arm equipped with 600 mm triple grouser shoe, 5400 kg counterweight

Lift-point height m		Lift-point radius								At max. Reach		
		3.0 m		4.5 m		6.0 m		7.5 m		Capacity		Reach m
												
7.5 m	kg					*7640	*7640			*7840	*7840	6.54
6.0 m	kg					*7990	*7990	*7850	6240	*7860	6150	7.57
4.5 m	kg			*11310	*11310	*9110	8610	*8170	6130	*8030	5330	8.19
3.0 m	kg			*14490	12350	*10560	8200	*8850	5950	7650	4920	8.50
1.5 m	kg			*15780	11730	*11840	7850	9090	5770	7490	4800	8.54
0.0 m	kg			*17320	11520	12520	7650	8960	5650	7730	4920	8.31
-1.5 m	kg	*11830	*11830	*16990	11520	12450	7590	8930	5620	8470	5360	7.79
-3.0 m	kg	*21430	*21430	*15740	11670	*11900	7670			*9980	6380	6.90
-4.5 m	kg	*17420	*17420	*12900	12020					*10330	9070	5.47

6.245 m boom, 3.1 m arm equipped with 600 mm triple grouser shoe, 5400 kg counterweight

Lift-point height m		Lift-point radius										A max. Reach				
		1.5 m		3.0 m		4.5 m		6.0 m		7.5 m		9.0 m		Capacity		Reach m
																
7.5 m	kg													*5600	*5600	7.26
6.0 m	kg							*7150	*7150	*7050	6350			*5380	*5380	8.20
4.5 m	kg					*9950	*9950	*8320	*8320	*7550	6200			*5390	4810	8.77
3.0 m	kg					*13150	12650	*9840	8300	*8330	5990	*6160	4530	*5590	4470	9.07
1.5 m	kg					*15780	11890	*11300	7910	9110	5770	6930	4430	*5980	4360	9.10
0.0 m	kg					*17040	11520	*12300	7640	8930	5620			*6660	4440	8.89
-1.5 m	kg	*7520	*7520	*11440	*11440	*17180	11430	12390	7530	8850	5550			7540	4780	8.40
-3.0 m	kg	*13170	*13170	*18390	*18390	*16380	11510	*12280	7550	8910	5600			8770	5520	7.59
-4.5 m	kg			*19840	*19840	*14300	11770	*10530	7750					*9750	7250	6.32

6.245 m boom, 3.75 m arm equipped with 600 mm triple grouser shoe, 5400 kg counterweight

Lift-point height m		Lift-point radius										A max. Reach				
		1.5 m		3.0 m		4.5 m		6.0 m		7.5 m		9.0 m		Capacity		Reach m
																
9.0 m	kg													*5010	*5010	6.61
7.5 m	kg									*5820	*5820			*4620	*4620	7.92
6.0 m	kg									*6230	*6230			*4490	*4490	8.78
4.5 m	kg							*7370	*7370	*6840	6260	*5880	4640	*4530	4360	9.32
3.0 m	kg					*11600	*11600	*8960	8410	*7700	6020	7040	4530	*4710	4070	9.60
1.5 m	kg					*14580	12050	*10570	7960	*8610	5770	6910	4400	*5050	3960	9.63
0.0 m	kg			*7450	*7450	*16410	11510	*11800	7620	8900	5570	6790	4300	*5610	4020	9.43
-1.5 m	kg	*7330	*7330	*11270	*11270	*17060	11300	12310	7440	8770	5460			*6540	4270	8.97
-3.0 m	kg	*11570	*11570	*16390	*16390	*16740	11310	12260	7400	8750	5440			7700	4830	8.21
-4.5 m	kg	*16730	*16730	*21870	*21870	*15310	11490	*11420	7520					*9250	6040	7.06
-6.0 m	kg			*16830	*16830	*11910	*11910							*9910	9490	5.25

- Lifting capacity is based on ISO 10567.
- Lifting capacity does not exceed 75% of tipping load with the machine on firm, level ground or 87% of full hydraulic capacity.
- The lift-point is where the bucket pivot mounting pin intersects with the arm (without bucket mass).
- (\*) indicates load limited by hydraulic capacity.













# HX300L/NL

## LIFTING CAPACITY

 Rating over-front  Rating over-side or 360 degrees











### HX300L

2-piece boom, 3.1 m arm equipped with 700 mm triple grouser shoe, 5400 kg counterweight













Lift-point height m		Lift-point radius										A max. Reach			
		3.0 m		4.5 m		6.0 m		7.5 m		9.0 m		Capacity		Reach m	
															
10.5 m	kg												*8440	*8440	3.54
9.0 m	kg					*6340	*6340						*6200	*6200	6.02
7.5 m	kg					*8590	*8590						*5490	*5490	7.44
6.0 m	kg			*8970	*8970	*9390	9140	*8410	6350				*5200	*5200	8.35
4.5 m	kg			*13240	*13240	*10510	8750	*8750	6180				*5130	4640	8.92
3.0 m	kg			*15540	12600	*11550	8270	*9340	5950	*7000	4480		*5230	4320	9.20
1.5 m	kg			*16850	11770	*12300	7840	9170	5720	6980	4390		*5510	4220	9.24
0.0 m	kg			*16650	11410	*12410	7560	8990	5560	*6410	4330		*6010	4310	9.03
-1.5 m	kg	*10230	*10230	*15260	11350	*11700	7460	8930	5500				*6880	4640	8.55
-3.0 m	kg	*15590	*15590	*12770	11480	*9970	7520	*7220	5590				*6590	5370	7.75
-4.5 m	kg	*20740	*20740	*15960	15690	*11880	10270						*11380	9900	6.17

### HX300NL

6.245 m boom, 2.5 m arm equipped with 600 mm triple grouser shoe, 5400 kg counterweight

Lift-point height m		Lift-point radius								A max. Reach		
		3.0 m		4.5 m		6.0 m		7.5 m		Capacity		Reach m
												
7.5 m	kg					*7640	*7640			*7840	7240	6.54
6.0 m	kg					*7990	*7990	*7850	5760	*7860	5670	7.57
4.5 m	kg			*11310	*11310	*9110	7920	*8170	5650	*8030	4910	8.19
3.0 m	kg			*14490	11220	*10560	7520	*8850	5470	7630	4530	8.50
1.5 m	kg			*15780	10630	*11840	7180	9070	5290	7480	4400	8.54
0.0 m	kg			*17320	10430	12490	6980	8930	5170	7710	4510	8.31
-1.5 m	kg	*11830	*11830	*16990	10430	12420	6930	8910	5150	8450	4910	7.79
-3.0 m	kg	*21430	20780	*15740	10570	*11900	7010			*9980	5850	6.90
-4.5 m	kg	*17420	*17420	*12900	10910					*10330	8280	5.47

6.245 m boom, 3.1 m arm equipped with 600 mm triple grouser shoe, 5400 kg counterweight

Lift-point height m		Lift-point radius										A max. Reach				
		1.5 m		3.0 m		4.5 m		6.0 m		7.5 m		9.0 m		Capacity		Reach m
																
7.5 m	kg													*5600	*5600	7.26
6.0 m	kg						*7150	*7150	*7050	5870				*5380	5040	8.20
4.5 m	kg					*9950	*9950	*8320	8040	*7550	5720			*5390	4430	8.77
3.0 m	kg					*13150	11510	*9840	7620	*8330	5510	*6160	4160	*5590	4110	9.07
1.5 m	kg					*15780	10770	*11300	7230	9080	5300	6910	4070	*5980	4000	9.10
0.0 m	kg					*17040	10420	*12300	6980	8910	5150			*6660	4070	8.89
-1.5 m	kg	*7520	*7520	*11440	*11440	*17180	10330	12360	6860	8830	5080			7520	4380	8.40
-3.0 m	kg	*13170	*13170	*18390	*18390	*16380	10410	*12280	6890	8890	5130			8750	5060	7.59
-4.5 m	kg			*19840	*19840	*14300	10660	*10530	7080					*9750	6630	6.32

- Lifting capacity is based on ISO 10567.
- Lifting capacity does not exceed 75% of tipping load with the machine on firm, level ground or 87% of full hydraulic capacity.
- The lift-point is where the bucket pivot mounting pin intersects with the arm (without bucket mass).
- (\*) indicates load limited by hydraulic capacity.















# HX300NL/LR

## LIFTING CAPACITY













 Rating over-front  Rating over-side or 360 degrees

### HX300NL

6.245 m boom, 3.75 m arm equipped with 600 mm triple grouser shoe, 5400 kg counterweight





















Lift-point height m		Lift-point radius												A max. Reach									
		1.5 m		3.0 m		4.5 m		6.0 m		7.5 m		9.0 m		Capacity		Reach m							
																							
9.0 m															*5010	*5010	6.61						
7.5 m	kg									*5820	*5820					*4620	*4620	7.92					
6.0 m	kg									*6230	5950					*4490	*4490	8.78					
4.5 m	kg									*6840	5770	*5880	4270			*4530	4010	9.32					
3.0 m	kg									*11600	*11600	*8960	7720	*7700	5540	7030	4160	*4710	3740	9.60			
1.5 m	kg									*14580	10930	*10570	7280	*8610	5300	6890	4040	*5050	3630	9.63			
0.0 m	kg									*7450	*7450	*16410	10410	*11800	6950	8870	5100	6780	3930	*5610	3680	9.43	
-1.5 m	kg	*7330	*7330	*11270	*11270	*17060	10210	12280	6780	8740	4990							*6540	3910	8.97			
-3.0 m	kg	*11570	*11570	*16390	*16390	*16740	10210	12230	6740	8730	4970							7680	4420	8.21			
-4.5 m	kg	*16730	*16730	*21870	20390	*15310	10390	*11420	6860											*9250	5520	7.06	
-6.0 m	kg				*16830	*16830	*11910	10810													*9910	8650	5.25

2-piece boom, 3.1 m arm equipped with 600 mm triple grouser shoe, 5400 kg counterweight

Lift-point height m		Lift-point radius								A max. Reach										
		3.0 m		4.5 m		6.0 m		7.5 m		9.0 m		Capacity		Reach m						
																				
10.5 m	kg														*8440	*8440	3.54			
9.0 m	kg														*6200	*6200	6.02			
7.5 m	kg														*5490	*5490	7.44			
6.0 m	kg														*5200	4730	8.35			
4.5 m	kg														*5130	4160	8.92			
3.0 m	kg														*5230	3860	9.20			
1.5 m	kg														*5510	3760	9.24			
0.0 m	kg														*6010	3840	9.03			
-1.5 m	kg	*10230	*10230	*15260	10000	*11700	6620	8700	4900									*6880	4140	8.55
-3.0 m	kg	*15590	*15590	*12770	10130	*9970	6680	*7220	4980									*6590	4800	7.75

### HX300LR

10.2 m boom, 7.85 m arm equipped with 800 mm triple grouser shoe, 6300 kg counterweight

Lift-point height m		Lift-point radius														A max. Reach										
		1.5m		3.0m		4.5m		6.0m		7.5m		9.0m		10.5 m		12.0 m		13.5 m		15.0 m		16.5 m		Capacity		Reach m
																										
13.5 m	kg																							*1340	*1340	12.84
12.0 m	kg																							*1270	*1270	14.05
10.5 m	kg																							*1230	*1230	15.01
9.0 m	kg																							*1200	*1200	15.77
7.5 m	kg																							*1200	*1200	16.36
6.0 m	kg																							*1210	*1210	16.79
4.5 m	kg																							*1230	*1230	17.07
3.0 m	kg																							*1270	*1270	17.23
1.5 m	kg																							*1330	*1330	17.25
0.0 m	kg																							*1410	*1410	17.13
-1.5 m	kg	*2070	*2070	*2790	*2790	*4630	*4630	*8440	6500	*6410	4890	*5160	3860	*4350	3130	*3780	2580	*3380	2150	*3070	1810	*2130	1530	*1510	1470	16.89
-3.0 m	kg	*2920	*2920	*3600	*3600	*5180	*5180	*8370	6210	*6820	4640	*5500	3650	*4610	2970	*3990	2460	*3530	2060	3070	1750			*1640	1500	16.50
-4.5 m	kg	*3780	*3780	*4500	*4500	*6010	*6010	*8920	6080	*7070	4490	*5730	3530	*4810	2860	4130	2380	3510	2010	3030	1720			*1830	1570	15.96
-6.0 m	kg	*4680	*4680	*5490	*5490	*7040	*7040	*9150	6070	*7170	4440	*5850	3470	4910	2810	4090	2340	3490	1990	*2670	1720			*2080	1690	15.26
-7.5 m	kg	*5660	*5660	*6600	*6600	*8300	*8300	*8980	6150	*7120	4470	*5840	3470	4910	2810	4100	2350	3510	2010					*2440	1870	14.36
-9.0 m	kg	*6740	*6740	*7870	*7870	*9850	9810	*8600	6310	*6870	4570	*5670	3540	*4760	2880	*4040	2410							*3020	2150	13.23
-10.5 m	kg	*7950	*7950	*9370	*9370	*10280	10200	*7930	6550	*6390	4750	*5270	3690	*4390	3010									*3690	2610	11.81
-12.0 m	kg				*11220	*11220	*8770	*8770	*6860	*6860	*5540	5020	*4500	3930										*3880	3470	9.96

- Lifting capacity is based on ISO 10567.
- Lifting capacity does not exceed 75% of tipping load with the machine on firm, level ground or 87% of full hydraulic capacity.
- The lift-point is where the bucket pivot mounting pin intersects with the arm (without bucket mass).
- (\*) indicates load limited by hydraulic capacity.

# BUCKET SELECTION GUIDE & DIGGING FORCE

## BUCKETS

SAE heaped (m³)	G	H	H+	RK	S	S+	SLR	Ditch	Slope
	1.05	0.60			1.07				
	1.17	1.08			1.23				
	1.28	1.24							
	1.40	1.35							
		1.40							
		1.51							
		1.20							
	1.41								

Capacity (m³)		Width (without cutter) mm	Weight kg	Tooth EA	Recommendation mm						
SAE heaped	CECE heaped				5900 mm Boom			2-piece Boom			
						2500 mm arm	3000 mm arm	3500 mm arm	2500 mm arm	3000 mm arm	3500 mm arm
						Counterweight 5500mm					
1.05	0.92	1369	770	G	●	●	●	●	●	●	●
1.17	1.00	1490	830	G	●	●	●	●	●	●	●
1.28	1.11	1604	870	G	●	●	●	●	●	●	●
1.40	1.22	1659	990	G	●	●	●	●	●	●	○
0.60	0.56	796	700	H	●	●	●	●	●	●	●
1.08	0.97	1246	925	H	●	●	●	●	●	●	●
1.24	1.11	1396	995	H	●	●	●	●	●	●	●
1.35	1.20	1498	1055	H	●	●	●	●	●	●	○
1.40	1.25	1546	1080	H	●	●	○	●	○	○	○
1.51	1.34	1646	1125	H	●	●	○	●	○	○	■
1.20	1.07	1121	1084	H	●	●	●	●	●	●	●
1.41	1.25	1273	1181	H	●	●	○	●	○	○	■
1.07	0.97	1244	1155	S	●	●	●	●	●	●	●
1.23	1.11	1394	1240	S	●	●	●	●	●	●	○

G: General Purpose  
 H: Heavy Duty  
 H+: Rock Heavy Duty  
 S: Mining  
 Flat: Flat bottom  
 SLR: Super Long Reach

- Applicable for materials with density of 2100 kg/m³ or less
- Applicable for materials with density of 1800 kg/m³ or less
- Applicable for materials with density of 1500 kg/m³ or less
- ▲ Applicable for materials with density of 1200 kg/m³ or less
- X Not Recommended

## DIGGING FORCE

Boom	Length	mm	5900mm Boom			2-piece Boom			Remark
			2.5 m	3.0 m	3.5 m	2.5 m	3.0 m	3.5 m	
Bucket Digging Force	SAE	kN	148 [162]	124 [134]	114 [124]	148 [162]	124 [134]	114 [124]	[ ]: Power Boost
		kg	15092 [16519]	12644 [13664]	11625 [12644]	15092 [16519]	12644 [13664]	11625 [12644]	
	ISO	kN	156 [169]	129 [139]	118 [129]	156 [169]	129 [139]	118 [129]	
		kg	15908 [17233]	13154 [14174]	12033 [13154]	15908 [17233]	13154 [14174]	12033 [13154]	
Arm Crowd Force	SAE	kN	153 [166]	153 [166]	153 [166]	153 [166]	153 [166]	153 [166]	
		kg	15602 [16927]	15602 [16927]	15602 [16927]	15602 [16927]	15602 [16927]	15602 [16927]	
	ISO	kN	179 [194]	179 [194]	179 [194]	179 [194]	179 [194]	179 [194]	
		kg	18253 [19782]	18253 [19782]	18253 [19782]	18253 [19782]	18253 [19782]	18253 [19782]	

# HX300

# BUCKET SELECTION GUIDE & DIGGING FORCE

## BUCKETS

SAE heaped (m³)	G	H	H+	RK	S	S+	SLR	Ditch	Slope
	1.27	1.51	1.60	1.16	1.45	1.45	0.59	0.45	0.55
	1.50	1.74	1.47		1.57			0.54	
	1.75	2.00							
		1.23							
		1.47							
		1.60							
		1.72							
		1.85							
		1.41							
	1.63								

Capacity (m³)		Width (without cutter) mm	Weight kg	Tooth EA	HX300L																HX300NL	HX300LR		
SAE heaped	CECE heaped				Boom 6250 mm				Boom 6250 HD				2-piece boom								6250			10200
					Arm mm																			
		2500	3100	3750	2500	3100	3750	2500	2850 HD	3100 HD	2500	3100	3750	2500	3100	3750	2500	3100	3750	7850				
		Counterweight 5400 kg				Counterweight 6300 kg				Counterweight 5400 kg				Counterweight 6300 kg										
1.27	1.1	1337	1095	G	●	●	●	●	●	●	●	●	●	●	●	●	●	●	●	-				
1.50	1.30	1547	1218	G	●	●	○	●	●	●	●	●	●	●	○	●	●	○	●	-				
1.75	1.5	1757	1320	G	●	○	■	●	●	○	●	●	○	○	■	■	●	○	■	-				
1.51	1.34	1344	1186	H	●	●	○	●	●	●	●	●	●	●	○	●	○	●	○	-				
1.74	1.54	1519	1275	H	●	○	■	●	●	○	●	●	○	○	■	■	●	○	■	-				
2.00	1.76	1714	1393	H	○	■	▲	○	○	■	○	○	■	■	▲	○	■	▲	○	-				
1.23	1.00	1174	1088	H	●	●	●	●	●	●	●	●	●	●	●	●	●	●	●	-				
1.47	1.30	1374	1191	H	●	●	○	●	●	●	●	●	●	●	○	●	●	●	○	-				
1.60	1.42	1474	1242	H	●	●	○	●	●	○	●	●	●	●	○	■	●	○	○	-				
1.72	1.53	1574	1313	H	●	○	■	●	○	●	●	○	○	○	■	●	○	■	○	-				
1.85	1.64	1684	1370	H	○	■	■	●	○	■	●	○	○	○	■	▲	●	○	■	-				
1.41	1.24	1219	1234	H	●	●	●	●	●	●	●	●	●	●	○	●	●	●	●	-				
1.63	1.43	1372	1339	H	●	○	○	●	●	○	●	●	●	○	■	●	●	○	○	-				
1.60	1.38	1614	1483	H+	●	○	■	●	●	○	●	●	●	○	■	●	○	○	■	-				
1.47	1.30	1374	1297	H+	●	●	○	●	●	●	●	●	●	○	○	●	○	○	○	-				
1.16	1.04	1433	1195	RK	●	●	●	●	●	●	●	●	●	●	●	●	●	●	●	-				
1.45	1.30	1362	1498	S	●	●	○	●	●	●	●	●	●	○	■	●	●	○	○	-				
1.57	1.40	1462	1560	S	●	○	■	●	○	●	●	●	●	○	■	●	○	○	■	-				
1.45	1.30	1362	1673	S+	●	●	○	●	●	●	●	●	●	○	■	●	●	○	○	-				
0.59	0.51	992	416	G	-	-	-	-	-	-	-	-	-	-	-	-	-	-	○					
0.45	0.37	1500	361	Ditch	-	-	-	-	-	-	-	-	-	-	-	-	-	-	●					
0.54	0.46	1800	408	Ditch	-	-	-	-	-	-	-	-	-	-	-	-	-	-	○					
0.55	0.45	1768	583	Slope	-	-	-	-	-	-	-	-	-	-	-	-	-	-	○					

- G: General Purpose
- H: Heavy Duty
- H+: Rock Heavy Duty
- S: Mining
- Flat: Flat bottom
- SLR: Super Long Reach
- Applicable for materials with density of 2100 kg/m³ or less
- Applicable for materials with density of 1800 kg/m³ or less
- Applicable for materials with density of 1500 kg/m³ or less
- ▲ Applicable for materials with density of 1200 kg/m³ or less
- X Not Recommended

## DIGGING FORCE

Boom	Length	mm	6245 m Boom				2-piece Boom			10020 m	Remark
			2.5 m	2.85 m	3.1 m	3.75 m	2.5 m	3.0 m	3.5 m	785 m	
Bucket Digging Force	SAE	kN	163 [177]	163 [177]	163 [177]	163 [177]	148 [162]	124 [134]	114 [124]	90	[ ]: Power Boost
		kg	16621 [18049]	16621 [18049]	16621 [18049]	16621 [18049]	15092 [16519]	12644 [13664]	11625 [12644]	9177	
	ISO	kN	199 [206]	199 [206]	199 [206]	199 [206]	156 [169]	129 [139]	118 [129]	102	
		kg	20292 [21006]	20292 [21006]	20292 [21006]	20292 [21006]	15908 [17233]	13154 [14174]	12033 [13154]	10401	
Arm Crowd Force	SAE	kN	154 [167]	144 [157]	127 [138]	113 [123]	153 [166]	153 [166]	153 [166]	52	
		kg	15703 [17029]	14684 [16009]	12950 [14072]	11523 [12542]	15602 [16927]	15602 [16927]	15602 [16927]	5302	
	ISO	kN	158 [172]	148 [161]	130 [141]	116 [126]	179 [194]	179 [194]	179 [194]	52	
		kg	16111 [17539]	15092 [16417]	13256 [14378]	11829 [12848]	18253 [19782]	18253 [19782]	18253 [19782]	5302	

# HX260/HX300

# STANDARD/OPTIONAL EQUIPMENT

FULL ELECTRO HYDRAULIC (FEH)	HX260	HX300
Variable Power Control	●	●
Electric Pump Flow Control	●	●
Electric MCV with Electric Joystick	●	●
Attachment Mode Flow Control	●	●
Engine Auto Idle	●	●
Engine Auto Shutdown Control	●	●
Joystick Steering	●	●

ISO STANDARD CABIN	HX260	HX300
Cabin Light (2 Working Lamp, HAL)	□	□
Cabin Light (2 Working Lamp, LED)	●	●
Cabin Light (6 Working Lamp, LED)	□	□
Cabin Upper and Lower Guard	□	□
Cabin Lower Guard	□	□
Cabin Rain Shield	●	●
Parallel Wiper	●	●
DAB Audio (Handsfree & Bluetooth)	●	●
Electric Horn	●	●
Safety Glass - Tempered Glass	●	●
Safety Glass - Laminated Glass (front)	●	●
Sliding Fold-In Front Window	●	●
Sliding Slide Window (LH)	●	●
Lockable Door	●	●
Hot & Cool Box	●	●
Storage Compartment	●	●
Comfort Package (Premium Seat included)	□	□
Multi Channel Speaker (4ea)	●	●

AUTOMATIC CLIMATE CONTROL	HX260	HX300
Air Conditioner & Heater	●	●
Defroster	●	●

AUTOMATIC STARTING AID	HX260	HX300
Starting Aid (Air Grid Heater) for Cold Weather	●	●
Engine Coolant Heater & Plug Heater(110V Plug Heater)	●	●
Engine Coolant Heater & Plug Heater(220V Plug Heater)	●	●

ADDITIONAL GAUGE PANEL (AGP)	HX260	HX300
12" LCD Display	●	●
12" LCD Display dual (Foldable, 2ea)	□	□
Engine Speed or Trip Meter / Accel	●	●
Engine Coolant Temperature Gauge	●	●
Max Power / Low&High Speed / Engine Check indicator	●	●
Auto Idle	●	●
Overload Warning with alarm	●	●
Eco Gauge / Fuel Level / Hyd. Oil Temperature Gauge	●	●
Air Cleaner Clogging	●	●
Fuel Warmer	●	●
Warnings	●	●
Communication Error	●	●
Low Battery / Clock	●	●

SEAT	HX260	HX300
Heating & Cooling Seat	□	□
Heating & Fabric	●	●
Premium Seat with Heating & Cooling	□	□

CABIN FOG (ISO 1,0262) LEVEL 2	HX260	HX300
FOG (Falling Object Guard) Front & Top Guard	□	□
Top Guard	□	□

CABIN ROPS (ISO 1,2117-2)	HX260	HX300
ROPS (Roll Over Protective Structures)	●	●

SAFETY	HX260	HX300
Battery Master Switch	●	●
Right and Rear View Camera	●	●
Smart Around View Camera (SAVM)	□	□
Travel Alarm	●	●
Beacon Lamp	●	●
Automatic Swing Brake	●	●
Boom Holding Valve	●	●
Arm Holding Valve	●	●
Overload Warning Device	●	●
Machine Guidance (MG)	□	□
Machine Guidance (MG) with 2D MG Laser Receiver	□	□
Weighing system with lift assist	□	□
Weighing system with advanced lift assist	□	□
Equipment Health Monitoring (EHM) - Basic	●	●
Equipment Health Monitoring (EHM) - Premium	□	□
Around Radar	□	□
Digital Key	□	□
Intelligence Package	□	□

NEW TECHNOLOGY	HX260	HX300
Microphone	□	□
Reversible Fan	●	●
Breaker Filter	□	□
Pre Cleaner - Oil washed	□	□
Fine Swing	□	□
Straight Travel Pedal	□	□
Hi MATE (Telematics)	●	●
Air Compressor	□	□
Auto Greasing System	□	□
Sid Protector & Catwalk	□	□
Fuel Filler Pump	●	●
Heat Wire for mirror	●	●
Shoe Case	□	□
Alarm for all with White Noise	●	●
Double-Acting Piping	●	●
Rotating Piping (PERO)	□	□
Bucket clamsell adaptation	□	□
Quick Coupler	□	□
Quick Coupler Piping	●	●
Tool Kit	□	□

BOOMS	HX260	HX300
5.9 m	●	-
5.9 m, HD (Heavy Duty)	□	-
2-piece boom	□	□
6.245 m	-	●
6.245 m, HD (Heavy Duty)	-	□
10.2 m Long Reach	-	□

ARMS	HX260	HX300
2.5 m	□	□
3.0 m	●	-
3.1 m	-	●
3.5 m	□	□
3.75 m	-	□
2.85 m, HD (Heavy Duty)	-	□
3.1 m, HD (Heavy Duty)	-	□
3.5 m, HD (Heavy Duty)	□	-
785 m Long Reach	-	□

COUNTERWEIGHT	HX260	HX300
5.4 ton	-	●
5.5 ton	●	-
6.3 ton	-	□
Heavy Duty Under Cover	●	●

TRACK SHOES	HX260	HX300
600 mm Triple Grouser Shoe	●	●
600 mm Double Grouser Shoe	-	□
700 mm Triple Grouser Shoe	□	□
800 mm Triple Grouser Shoe	□	□
900 mm Triple Grouser Shoe	□	□

\* Standard and optional equipment may vary. Contact your Hyundai dealer for more information. The machine may vary according to International standards.

\* The photos may include attachments and optional equipment that are not available in your area.

\* Materials and specifications are subject to change without advance notice.

- Standard
- Optional
- Not available





HYUNDAI

HYUNDAI

HX260

# HYUNDAI

In Europe, Hyundai is operated and managed by:

HD Construction Equipment Hyundai Europe, Hyundailaan 4,  
3980 Tessenderlo-Ham, Belgium T +32 14 56 22 00 E info@hyundai.eu  
www.hyundai-ce.eu VAT BE0454495082

The information and data contained in this brochure is the property of HD Construction Equipment Hyundai Europe and has been compiled with the utmost care. Specifications and designs are subject to change at any time without notice. As general data, images and descriptions have been used in the brochure, Hyundai products may be fitted with non-standard equipment. The publication of this brochure cannot be regarded as an offer or proposal to contract and is intended for European markets only.



Scan to find out more  
about this product.

Contact your Hyundai dealer.  
[hyundai-ce.eu/en/dealer-locator](http://hyundai-ce.eu/en/dealer-locator)

## TELAKONE

PART OF FINNSIIRTO GROUP

HY-CE-00770. 02/2026. EN. ISSUE 1

### Telakone Humppila

#### Päätoimipiste

Konemyynti:  
[telakone@telakone.com](mailto:telakone@telakone.com)  
Kennintie 7, 31640 Humppila  
Puh. 029 7031 9701  
[www.telakone.fi](http://www.telakone.fi)

### Telakone Helsinki

#### Pääkaupunkiseudun toimipiste

Konemyynti:  
[telakone@telakone.com](mailto:telakone@telakone.com)  
Juvankartanontie 15, Espoo  
Puh. 029 7031 9701  
[www.telakone.fi](http://www.telakone.fi)

### Telakone Tampere

#### Pirkanmaan toimipiste

Konemyynti:  
[telakone@telakone.com](mailto:telakone@telakone.com)  
Ajurintaival 10, 33880 Lempäälä  
Puh. 029 7031 9701  
[www.telakone.fi](http://www.telakone.fi)

### Telakone Lieto

#### Varsinais-Suomi / Turku

Konemyynti:  
[telakone@telakone.com](mailto:telakone@telakone.com)  
Vakiotie 11, 21420 Lieto  
Puh. 029 7031 9701  
[www.telakone.fi](http://www.telakone.fi)

>> Simeri, Finnsiirto Oy ja Telakone keskittävät toimintonsa uusiin toimitiloihin Espooseen (Kiilaniityntie 10) kevään 2026 aikana.